

# SAMUEL HEATH

**Product Number:** T12K16LA-S40

**Description:** 3 Hole basin filler, 210mm spout height, high spout

## Standards



## Flow rates

Litres/Min	0.1 Bar	0.5 Bar	1.0 Bar	2.0 Bar	3.0 Bar	4.0 Bar	5.0 Bar
		1.8	2.5	3.8	4.0	4.0	4.0

Flow rate data provided is indicative of each product and is given in open outlet conditions. Installation design, external connections and fittings not supplied may affect the data provided.

## Finishes Available



Chrome Plate



Polished Nickel



Stainless Steel Finish



Stainless Steel with Matt Black



City Bronze



Matt Black Chrome



Brushed Gold Matt



Polished Nickel with Gloss Black Chrome



Brushed Gold Matt with City Bronze



Stainless Steel Finish with City Bronze



Antique Gold with Gloss Black Chrome



Antique Brass Matt



Anthracite

## Control Options Available



## Specification Drawing

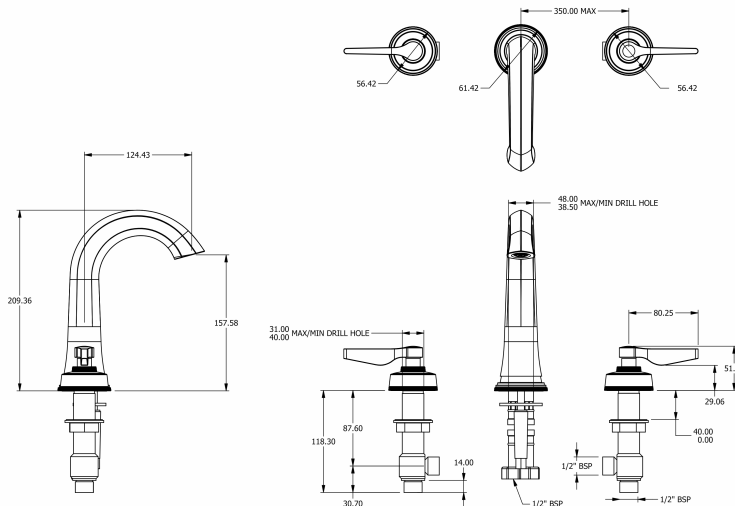

### UK Customer Service

Leopold Street  
Birmingham  
B12 0UJ  
Tel: +44 121 766 4200  
Email: info@samuel-heath.com

### US Customer Service

Federal I.D. No. 58-1504682  
Email: usa@samuel-heath.com

### Specification Enquiries

Design Centre Chelsea Harbour  
1st Floor, North Dome, London  
SW10 0XE  
Tel: 020 7352 0249  
Email: showroom@samuel-heath.com